**MISTIFYER SENIOR ANTI-DRIP™
SYSTEM**

Operating Instructions

P/N 100073 (230V P/N 100082)

- **Thank you for purchasing this Mistifyer Senior Anti-Drip™ System**
- **As you will notice from the table of contents, the manual for your new pump is quite extensive. To guarantee perfect and successful work with this machine, please take time to read the manual carefully.**
- **Do not operate before changing oil cap!**
- **And finally, we believe you will enjoy many years of dependable, trouble free service if you properly install and maintain this powerful piece of machinery called the Mistifyer Senior Anti-Drip™ System**

CITC
1420 80th Street SW Suite #D
Everett, WA 98203
(888) 786-CITC
www.citcfx.com

Contents

1.	Equipment Supplied	3
2.	Accessories and Parts	3
3.	Safety information	4
4.	Grounding Instructions	4
5.	Receiving and Unpacking	4
5.1	Checking for Damage in Shipping	
5.2	Checking Inventory of Parts	
6.	Pump Start-up Procedure	5
6.1	Oil Reservoir Cap Replacement	
6.2	Pump Preparation	
7.	Hooking up the Pump	6
7.1	Installation of Pump	
7.2	Water Supply	
7.3	Water Filter Installation	
7.4	Anti-Drip Extension	
8.	Mist Line Layout Strategies	8
8.1	Light, Medium or Heavy Haze	
8.2	Indoor Fog Curtains	
8.3	Raise Humidity to Keep Dust Down	
8.4	Project Images and Lasers	
9.	Mist Line Assembly	8
9.1	Tubing Connection	
9.2	Pre-Installation System Test	
9.3	Pressure Regulation	
9.4	Checking for Leaks	
9.5	Adjusting the Fog Pattern	
9.6	Mounting the Mist Line	
10.	Maintenance procedures	11
10.1	System Pressure	
10.2	Changing the Pump Oil	
10.3	External Water Filter Inspection	
10.4	Drive Belt Inspection	
11.	Troubleshooting	12
11.1	Low Pressure	
11.2	Water continues to run through pump after pump is turned off	
11.3	Pump stops running	
11.4	Oil leaking around pump	
11.5	Pulsation	
11.6	Water leaking from under manifold	
11.7	Water in crankcase (looks like bubbles, or milky color)	
12.	Technical Data	14
13.	Warranty	15

1. Equipment Supplied

- Mistifyer Senior Anti-Drip™ System P/N 100073 (230V P/N 100082)
(Please see section 5.2 for a complete checklist.)

2. Accessories and Parts

100069	Anka's 220v 50 hz 2qpm 1.5hp Pulley Drive 70-nozzle
100068	10 Nozzle Anti-Drip Pump Kit 12 VDC
250042	Universal DMX Relay 3-pin XLR, Heavy Duty
600720	Filter Housing with Bracket Kit
600721	5-Micron Sediment Filter Cartridge
600722	1.5" Automatic Drain Valve
600723	.008 Nozzle with 10/24 Thread
600724	.012 Nozzle with 10/24 Thread
600725	Push Connector Quick Device - Tee Only (included)
600726	Push Connector Quick Device - Tee with Fine Nozzles (.008)
600727	Push Connector Quick Device - Tee with Heavy Nozzles (.012)
600728	Nylon Tubing 3/8" OD (1cm) (price per foot)
600729	Nylon Tubing 3/8" OD (1cm) (28" length, included (71.1cm))
600730	Nylon Tubing 3/8" OD (1cm) (50' roll (15.2m))
600731	Nylon Tubing 3/8" OD (1cm) (100' roll (30.5m))
600732	Tubing Cutter
600733	Push Connector Quick Device - Brass Hose Adapter
600734	Push Connector Quick Device - End Plug (included)
600735	Push Connector Quick Device - 3/8" MIP Adapter (included)
600736	Push Connector Quick Device - Brass 90 Elbow (included)
600737	Push Connector Quick Device - Three-way Tee (included)
600738	Push Connector Quick Device - 4-Way Cross
600739	½" Brass Nozzle Extension
600740	1½" Brass Nozzle Extension
600741	8 oz. Bottle of Nozzle Cleaner (0.24 liter)
600742	1 Gallon Bottle of Nozzle Cleaner (3.8 liter)
600743	Anti-Drip Extension with .008 (included)
600744	Anti-Drip Extension with .012
600746	3/8" (1cm) Steel Clamp Vinyl-Coated Tie Wraps (included)
600747	10/24 Nozzle Plug
600748	.008 Nozzle O-Ring (Red) (included)
600749	.012 Nozzle O-Ring (Black)
600751	¼" HP Solenoid Valve 120 N.O. with Setup
600752	Push Connector, coupling
600754	5-Nozzle Mist Pod without Nozzle
600755	Push-Connector Quick Device Brass Union
600756	2000 PSi Pressure Gauge
600758	Labor Pump Assembly
600759	10' Low-Pressure Tubing (3m)
600760	5' Low-Pressure Tubing with Hose Adapter (1.5m)
600761	3' Low-Pressure Tubing for Filter to Pump (90cm)
600762	2' Low-Pressure Tubing for Drain to Bucket (60cm)
600763	1 Gallon Bottle (Drain Container)
600764	Oil Plug with Warning Sign
600765	Mistifyer Instruction Booklet and Price Sheet
600766	Set of 4 Wheels
600768	2X Push-Connector Auto Drain-down (anti-freeze)
600770	Pump Water Seal Kit
600771	6 Valve Rebuild Kit
600780	5 head nozzle .008 w/ anti-drip adapter
600781	5 head nozzle .012 w/ anti-drip adapter
600782	Push-con Union
600783	Pressure Relief Switch Control (for 150 nozzle)

3. Safety Information

3.1 **WARNING:** Read through the entire instructions before attempting installation.

- **Risk of electrical shock** - This pump is supplied with a grounding conductor. To reduce risk of electrical shock, connect only to a properly grounded, grounding type receptacle.
- Have a qualified electrician wire the pump to a dedicated, fused circuit.
- Install pump on a flat, level, solid foundation. This pump is non-submersible.

3.2 **CAUTIONS:**

- **Before operation, replace non-vented oil reservoir cap with vented one which you will find shipped in the electrical junction box. Failure to replace this cap will void the warranty. Pump must be able to breathe.** (See section 6.1 for more details.)
- **Pump warranty is voided by failure to use factory- supplied filter on water supply! Water filter is installed on water INLET line!** (See section 7.3 for more details.)
- **To reduce risk of electric shock, disconnect power before servicing this pump.**
- Maximum design pressure is 800 PSI (55 bar) continuous. Under no circumstances should the pressure be allowed to go higher than 1000 PSI (69 bar)!
- This pump has been evaluated for use with water only. Do not use with any other liquids.
- To reduce risk of electric shock, install with all electrical components well-grounded and dry.

4. Grounding Instructions

4.1 **The pump should have a dedicated circuit**

4.2 **The pump MUST BE GROUNDED!** In the event of a malfunction or breakdown, grounding will reduce the risk of electric shock by providing a path of least resistance for the electric current. Install electrical hookup in accordance with all local codes and ordinances. **Warning:** Improper connection of the equipment-grounding conductor can result in a risk of electric shock. Check with a qualified electrician if you are in doubt whether the pump is properly grounded. Never use a two-prong outlet or cut off the third prong on the plug!

5. Receiving and Unpacking

5.1 **CHECKING FOR DAMAGE IN SHIPPING**

- Carefully examine contents for signs of damage in shipping. Immediately notify the carrier if damage is detected that was not visible upon receipt of shipment.

5.2 CHECKING INVENTORY OF PARTS

CITC ITEM #	QTY.	PART DESCRIPTION	Received
	1	JMS AD – 5gpm 5hp Pump Assembly	
600720	1	Filter Housing with Bracket Kit	
600721	1	5-Micron Sediment Filter Cartridge	
600725	200	Push Connector Quick Device – Tee Only	
600729	200	Nylon Tubing 3/8" OD (1cm)((28" Length)(71.1cm))	
600730	1	Nylon Tubing 3/8" OD (1cm)((50' Roll)(15.2m))	
600731	3	Nylon Tubing 3/8" OD (1cm)((100' Roll)(30.5m))	
600732	1	Tubing Cutter	
600733	1	Push Connector Quick Device – Brass Hose Adapter	
600734	20	Push Connector Quick Device – End Plug	
600736	15	Push Connector Quick Device – Brass 90 Elbow	
600737	15	Push Connector Quick Device – Three Way Tee	
600743	200	Anti-Drip Extension with .008	
600746	375	3/8" Steel Clamp Vinyl Coated with Tie Wraps	
600759	6	Feet Low Pressure Tubing	
600764	1	Oil Plug with Warning Sign	
600765	1	Mistifyer Senior Anti-Drip™ System Instruction Booklet	
600738	4	4-way Tee Push Connector	
600783	1	Auto shut-off water pressure safety switch (optional accessory)	

6. Pump Start-up Procedure

6.1 OIL RESERVOIR CAP REPLACEMENT

- The unit is shipped with a non-vented oil reservoir cap. The unit has to be sealed in order to prevent leakage of the oil during shipping. In order to operate the unit, YOU MUST REPLACE THE NON-VENTED CAP WITH THE ENCLOSED VENTED OIL RESERVOIR CAP (BREATHER CAP).
- Operation of the machine without removing the plug and replacing it with the breather cap WILL VOID THE WARRANTY. Do not operate this unit until the breather cap has been installed. To replace the non-vented cap first find the breather cap, which is shipped in the electrical junction box.
- LOOSEN THE SCREWS ON THE COVER, REMOVING IT ENTIRELY. On top of the pump, next to the motor is a cap where the oil is added. Remove the cap, replacing it with the breather cap provided.
- Keep the non-vented cap where you can find it as you will need to install it again before sending the unit by freight. Replace the vented cap with solid plug cap for any transport to prevent oil spillage.

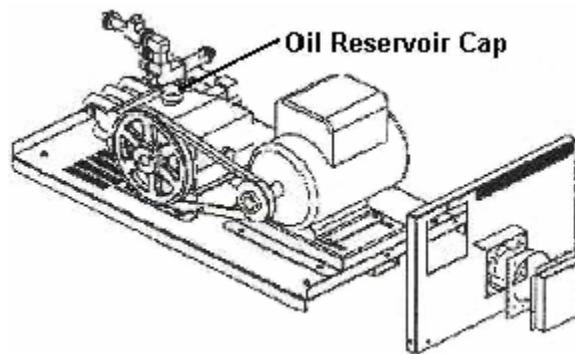

6.2 PUMP PREPARATION

- Check belt tension to insure belt has not loosened during shipping. It should not move more than $\frac{1}{2}$ " (13mm).
- Check oil level with dipstick and sight gauge. The proper level is $\frac{1}{2}$ full on sight gauge. You may also use the dip stick on the breather valve. This is where you may add 30 wt. non-detergent oil when needed. Check the oil each 200 hours of operation.
- The switch for the pump is located on the outside of the side cover containing the inlet and discharge lines and the pressure gauge.

7. Hooking up the Pump

7.1 INSTALLATION OF PUMP

- The pump should be set inside a covered area on a level surface such as a stage or platform. Having the pump level will insure proper lubrication to the internal parts in the pump. Do not set it on a soft surface as the vibration will sink the unit.

7.2 WATER SUPPLY

- Insure that the water source being used can supply enough water for the demand of the pump. Use a minimum $\frac{3}{4}$ " hose (19 mm) with at least 40 PSI (2.8 bar) of clean water.

7.3 WATER FILTER INSTALLATION

- NOTE! Use factory-supplied water filter in water supply to the pump. Contaminants in water can damage pump and plug nozzles if filter is not used!

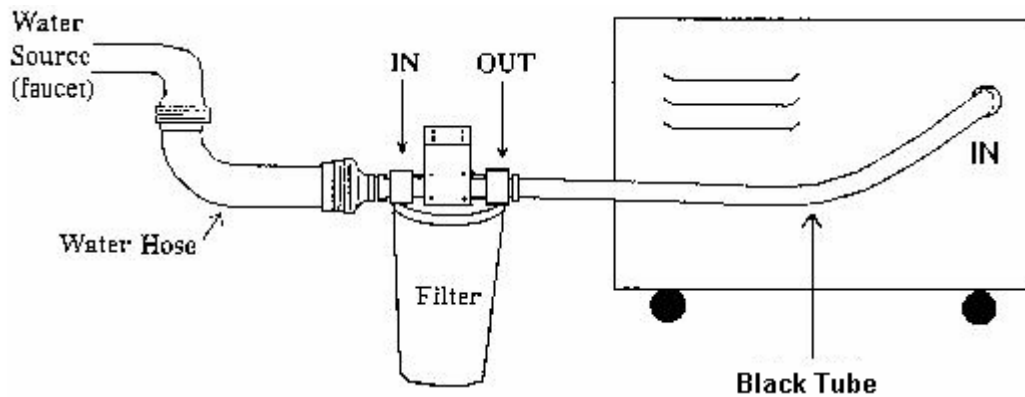

- Connect the larger water supply line to the CITC filter assembly (mount near the pump, possibly on frame of a dolly or a wall if permanently installed). Simply push the hose onto the filter. Connect the opposite end of the tubing to your water hose.
- Before connecting to pump, run water through the hose, then the CITC filter for thirty seconds to flush the line and avoid any contaminants entering the pump, then connect the 3-foot long tubing from the filter to the “IN” connection on the pump.
- If using a new hose, rinse the hose for ½ hour to flush out odors.

7.4 ANTI-DRIP EXTENSION

- With anti-drip, you can stop drips from occurring when stopping and starting the Mistifyer Senior Anti-Drip™ System. Each time you stop the system, the auto-drain valve removes a slight amount of water to reduce pressure (1/4 cup) to drain into the bucket supplied. For testing, place a bucket at rear of pump under tube coming out of the machine in the back marked DRAIN. For permanent installation run a hose from the DRAIN outlet to a convenient sewer drain.

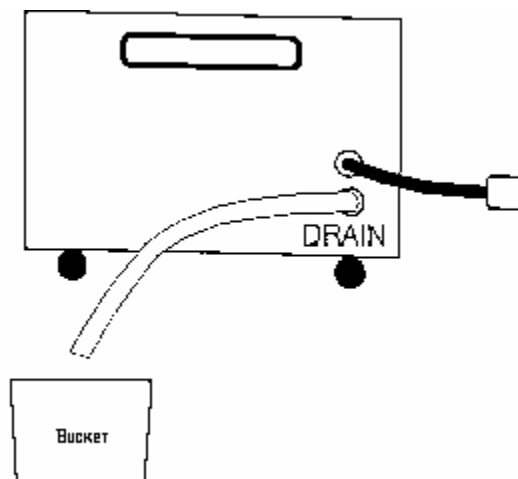

- When using the anti-drip system, do not install auto-drain valves (not supplied). (The auto-drain valves, used with the regular Mistifyer System™, are installed in line with the nozzles to drain the mist line for protection from freezing damage when not in use.)

8. Mist Line Layout Strategies

8.1 LIGHT, MEDIUM OR HEAVY HAZE

- Light – Use 180 – 200 fine nozzles (0.008")
- Medium – Use 120 fine, 50 heavy nozzles (0.012"), alternating every 2 or 3 fine nozzles with a heavy nozzle.
- Heavy Haze Mist – Use 150 heavy nozzles (0.012") for thickest mist in low humidity areas.
- Note: the driest mist will be the light mist. Order heavy nozzles for medium or heavy haze.

8.2 INDOOR FOG CURTAINS

- Use 200 fine nozzles pointed straight down for the driest mist. If wetness is not a problem, mix for medium or heavy, being sure to point nozzles down from high position. Downdraft can pull in fog from fog machines adding another dimension.

8.3 RAISE HUMIDITY TO KEEP DUST DOWN

Point nozzles away from anything close by – mist shoots away up to 6' – 8' (1.8 – 2.4m) in cone shape of 18" (46cm) diameter. Alternate nozzles horizontally pointing opposite directions to reduce dust from the air. This added moisture removes dust by clinging to the dust and dragging it down out of the air, making the air smell fresh and clean.

8.4 PROJECT IMAGES AND LASERS

- Hang nozzles in a straight line at 18' – 20' (5.1 – 6.1m) high, pointing downward. The 200 fine nozzles will need to be closer together. Cut tubing 6" – 12" (15 – 30 cm) shorter, testing thickness of screen necessary. Once in place, be sure all nozzles are pointed straight down without wind or air movement. Project from rear of water screen, being sure no other lights are illuminating the screen, unless for effect.

9. Mist Line Assembly

9.1 TUBING CONNECTION

- Use the supplied cutters to begin cutting the supplied high-pressure (black) tubing to the required lengths (see recommended lengths below). Be sure to measure the total length required for the mist line before cutting the tubing. Only cut what is needed.

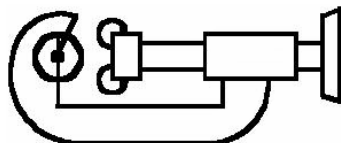

- **RECOMMENDED NOZZLE SEPARATION**

Mounting Height	Nozzle Separation
8 – 10' (2.4-3m)	28" (71cm)
10-15' (3-4.5m)	24" (61cm)

- Begin assembling the mist line by taking one of the supplied Push-Con "T" Nozzle assemblies with the precut tubing and push the nylon tubing in to the next Push-Con "T" with precut tubing, being sure to completely push into the fittings. Hold the ring from moving and push again with a slight ¼ twist. Feel it seat completely. Let loose of the ring then pull to test for tightness.

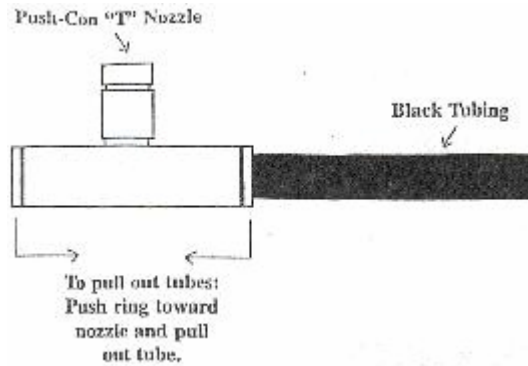

9.2 PRE-INSTALLATION SYSTEM TEST

- Once the mist line is completely assembled, and before attempting to mount the mist line, the system should be flushed (section 4.3) and pressure tested.
- Insert an end plug into the last Push-Con fitting. Connect the pump end of the mist line to the pump by inserting the tubing into the Push-Con "OUT" fitting marked on the side of the pump.

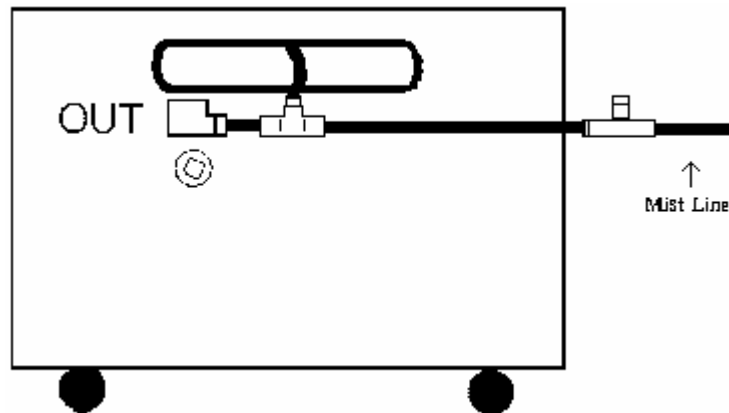

- Turn the pump on making sure of proper pressure (600-800 PSI) (42-55 bar). This will cause the tubing to expand from the fittings, eliminating any sagging once the mist line is mounted.

9.3 Pressure Regulation

- The pressure regulator has been factory preset to 800 PSI (55 bar). If you hook up less than 200 heads or if the line voltage is out of spec, you may be outside

the recommended operating pressure range of 600-800 PSI (42-55 bar). If you reduce the number of nozzles, you will increase pressure. **UNDER NO CIRCUMSTANCES SHOULD THE PRESSURE EXCEED 1000 PSI (69 bar)**, as this can rupture lines and cause damage to seals and pump. See section 10.1 to adjust the operating pressure.

9.4 Checking for Leaks

- Check for leaks that may have occurred due to the tubing not being inserted beyond the O-ring seal. In case of a leak, turn the pump off and remove the leaking fitting. Then insert the tubing back into the fitting making sure the tubing inserts beyond the O-ring. When removing the Push-Con fitting, use a 3/8" (open-end wrench against the ring, holding the connector with your thumb.
- If you still have leaks, remove the tubing and touch the edge of the tubing for sharpness. If sharp, check the O-ring inside the push-conn fitting to see if it has been cut. Soften the edges of the tubing with a file and try again. Be sure to push in as you give a twist. Hold the outer ring of the push-conn fitting to seat the tubing securely.

9.5 Adjusting the Fog Pattern

- As you retest, watch the flow of fog and how it shoots to help you determine the pattern you would like to see when you mount it in a different position. If you are doing several shapes or changes, use a 3/8" open-end wrench again to hold against the ring while you pull it apart.



9.6 Mounting the Mist Line

- The mist line is now ready to be mounted. The mist line could be mounted to the underside (bottom) of the structure to be fogged or laid on the ground pointing up, or hung from a cable or a two-inch pipe with tie-wraps, over rough terrain, or....wherever. When mounting, keep flexibility a key factor. You may want to change your mind. Note: When supporting this line of spray nozzles, tie a support on each side of the nozzle about 3" (8cm) back, allowing room for change

later. Pull the mist line tight as you secure each strap. The unique Push-Con “T” design allows complete 360 degree adjustability of the spray from each nozzle independently. Once the pressure is off, the nozzle may be turned to any angle. To be sure turning doesn’t affect the other nozzles, hold the tubing while you turn the direction of the nozzle.

- The next step is to run a feed line from the beginning of the mist line using the remainder of the flexible tubing supplied. Insert the feed line into the Push-con “out” fitting located on the end of the pump. Run the feed to the origination point of the mist line, securing the line every two feet (61cm) with the tubing straps. Be careful not to crimp or twist the line. Trim any excess feed line with the supplied tubing cutters and insert the feed line, usually 25 – 300ft (9 – 105m) into the first Push-Con “T” fitting on the mist line. If any elbows are required in your feed or mist line, connect them in the same manner as the “T” fittings.
- Note on permanent installations: when connecting pump to stainless or copper tubing install a flexible discharge hose between pump and tubing to reduce vibration to piping.

10. Maintenance procedures

10.1 SYSTEM PRESSURE

- Your pump includes a 2000 PSI (138 bar) high-pressure glycerine-filled gauge and an adjustable unloader valve. Check the system pressure periodically during operation. The operating pressure should be between 600-800 PSI (42-55 bar). **DO NOT EXCEED 800 PSI (55 bar)!** Note: an air bubble will be inside the pressure gauge. This is normal.
- To adjust pressure you will need two 5/8” open-end wrenches. Keep the bolt from turning with one wrench while loosening the jam nut with the other. Then adjust pressure by turning the adjustment bolt while operating, counter-clockwise to reduce, clockwise to increase. Re-tighten jam nut.
- If you do this while it is operating, be very careful of the turning belt and pulleys. Adjust until at 800 PSI (55 bar) on the gauge. Turn off power. Then tighten jam nut. Cover unit and screw down cover.



**Pressure
Adjust**

10.2 CHANGING PUMP OIL

The pump oil should be changed every 500 hours of operation. To change the oil do the following:

- Run pump for 1 hour prior to changing the pump oil. This will heat the pump, causing the oil to flow better when removing from the pump.
- To avoid electrical shock, disconnect power supply and then continue by removing the pump cover.
- Remove the breather cap located on the topside of the pump.
- Locate the oil drain tube on the bottom side of the pump, remove the 1/8" drain cap and drain the oil into a container.
- After draining is completed, replace drain cap and fill pump with Non Detergent Pump Oil. The pump will take 34 ounces. Oil will show ½ way in sight window when pump is full.
- Replace breather cap (hand tight) and pump cover.
- Run unit for 1 minute and shut off. Let sit for 3 minutes.
- Recheck site glass for proper level. Unit is ready for operation.

10.3 EXTERNAL WATER FILTER INSPECTION

- Shut down water supply to pump before inspecting the filter element.
- To insure the long life of the pump the external filter element needs to be inspected and/or replaced every 6 months or as needed. The time in between replacements will vary with more use of the system and quality of water. If in an area of hard mineral water, change the filter more often.

10.4 DRIVE BELT INSPECTION

- The belt should not loosen from vibration of the pump, however, when changing the oil, check the belt tension and inspect for cracks or abnormal wear.
- The belt should never be more loose than to allow a movement of ½" (13mm) in the center between the pulleys.

11. Troubleshooting

11.1 Low Pressure

- Check number of nozzles – too many will lower pressure and cause the pump to work too hard.
- Leak in line on discharge side: inspect all nozzles, lines and fittings for leaks.
- Insufficient supply of water: increase flow of supply line and check water filter.
- Fouled or dirty inlet or discharge valves: clean inlet and discharge valve assemblies.
- Worn inlet, discharge valve blocked or dirty: replace worn valves, valve seats and/or discharge hose.
- If nothing else works – Unloader valve not properly adjusted: increase pressure by turning unloader clockwise. (See Section 10.1).

11.2 Water continues to run through pump after pump is turned off

- Contaminant lodged in solenoid valve: remove solenoid and plunger and dislodge any foreign matter. Disconnect power. Inlet solenoid valve is located near the inlet where water first comes into the unit. The first solenoid valve stops water from coming when the power is off.
- Remove the upper electrical magneto by sliding the C-clip sideways and lifting off the stem the entire unit. Tap on the solenoid lightly with a wrench. Disconnect the hose pressure and squirt water inside to remove dirt. Place magneto back on with C-clip and try again.

11.3 Pump stops running

- Overloading the circuit: confirm that pump is plugged into a dedicated circuit and has sufficient amperage. Also be certain that sufficient water pressure is available. Use a minimum ¾" hose (19 mm) with at least 40 PSI (2.8 bar) of clean water.

11.4 Oil leaking around pump

- Drain cap loosened: tighten drain cap with 9/16 wrench.
- Red dipstick loosened: tighten dipstick hand tight.
- Seals possibly leaking. No oil breather plug.

11.5 Pulsation

- Valve stuck open: check all valves, remove foreign matter and reassemble.
- Belt slippage: tighten or replace, use correct belt.

11.6 Water leakage:

- **(from under manifold)** Worn packing, cracked plunger: install new packing or replace plungers. (Factory authorized dealer.)
- **(from excess vapor)** Check humidity—over 70% creates lack of evaporation, possible drips from dampness build-up on equipment or floors. Run unit less. Exhaust excessive humidity and bring in fresh air that is dryer or add a dehumidifier.

11.7 Water in crankcase (looks like bubbles, or milky color)

- May be caused by humid air condensing into water inside the crankcase: shorten oil-change intervals, replace O-rings.
- Be sure breather oil cap is being used.

12. Technical Data

Mistifyer Senior Anti-Drip™ System P/N 100073 (230V P/N 100082)	
Case Dimensions	37" x 19.5" x 15" (94 cm x 49.5 cm x 38.1 cm)
Weight	160 lbs (72.6 kg)
Shipping Weight	250 lbs (110 kg)
Motor HP	5 hp
Electrical Power (single-phase)	208VAC, 60 Hz, 18-23 Amp 230VAC, 50 Hz, 18-23 Amp
Output	4.89 gpm @ 800 PSI (18.6 liter per minute at 55 bar)
Maximum Pressure	800 PSI (55 bar)
Minimum Inlet Pressure	40 - 125 PSI (no less than 40 PSI) 2.8 – 8.6 bar (no less than 2.8 bar)
Oil Capacity	34 oz (1 liter)
Oil Type	Non-detergent 30W
Oil Change	200 hrs
Limited Warranty	One (1) year
Rev 2/14/2005	

Nozzle	GPM at 800 psi	O-Ring
.006	.0135	Yellow
.008	.0216	Red
.012	.0317	Black
.015	.0450	Brown
.020	.0900	Green

13. Limited Warranty Conditions Mistifyer Senior Anti-Drip™ System

- 1. Subject to the following conditions we will repair any defect or fault in the unit if it is caused by a proven factory fault and has been advised immediately after appearance and within 30 days of delivery to the end user. Insignificant deviations of the regular product quality does not guarantee replacement rights, nor do faults or defects caused by water, by generally abnormal environment conditions or Force Majeure.**
- 2. A Limited One-Year Warranty will be done in the following way: Faulty parts will be repaired or replaced (our choice) with correct parts. Faulty units have to be shipped to us or sent to us at customer's expense. The RMA# has to come with the faulty, unit, obtained from CITC.**
- 3. The customer loses all rights for Limited Warranty services, if any repairs or adjustments are done to the units by unauthorized persons and/or if spare parts are used, which are not approved by us. Also, non-compliance with the instructions in this manual or mistakes by incorrect handling/treating of the machine, any faults and damages caused by undue force will lead to a loss of limited warranty.**
- 4. Freight costs to and from CITC when under the limited warranty services are the responsibility of the customer.**
- 5. Limited warranty services do not cause an extension of the limited warranty time or the start of a new limited warranty time. The warranty of replaced parts ends with the limited warranty time of the whole unit.**
- 6. If a defect/fault can not be repaired by us in a satisfactory time, we will, within 30 days after sale of the unit, our choice either:**
 - Replace the whole unit for free or**
 - Refund the lesser value or**
 - Take back the whole unit and refund the purchase price, but not more than the usual market price at the time of refund.**
- 7. Further claims, especially for damages, losses etc. outside the unit are excluded.**
- 8. Your limited warranty coverage is based on completion of the warranty card and returning it with your proof of purchase within 30 days of purchase.**

Your limited warranty coverage is based on completion of the warranty card and returning it with your proof of purchase within 30 days of purchase. If you should send the unit for service, do not forget to replace the vented oil cap with the non-vented cap used for shipping the unit. Also drain water from system. Obtain your RMA # by calling CITC. Payment arrangements for repair must be made before receiving RMA # in case unit is not covered under Limited Warranty.

Send unit to:

**CITC
RMA # XXXXXXX
1420 80th Street SW Suite #D
Everett, WA 98203
Tel: (888) 786-CITC or (425) 776-4950
Fax: (425) 776-5129
Website: www.citcfx.com
E-mail: info@citcfx.com**



**1420 80th Street SW Suite #D Everett, WA 98203
425-776-4950 ✧ FAX: 425-776-5129
www.citcfx.com ✧ info@citcfx.com**