

---

---

**FOAM DOME™**  
**Operating Instructions**

---

---

**P/N 100212 (230 VAC)**

## **Thank you for purchasing this FOAM DOME™**

- **As you will notice from the table of contents, the manual for your new product is quite extensive.**
- **To guarantee perfect and successful work with this machine, please take some time to read the manual carefully.**
- **And finally, we believe you will enjoy years of great foam effects if you care for and maintain your FOAM DOME™.**

**CITC**

**2100 196<sup>th</sup> St. S.W., Ste. 138**

**Lynnwood, WA 98036**

**(888) 786-CITC**

**[www.citcfx.com](http://www.citcfx.com)**

# Contents

<b>1. Set of Equipment Supplied</b>	<b>3</b>
<b>2. Accessories</b>	<b>3</b>
<b>3. Description</b>	<b>4</b>
<b>4. Safety Instructions</b>	<b>4</b>
<b>5. Operating the Foam Dome™</b>	<b>5</b>
<b>5.1 Selecting the location</b>	
<b>5.2 Electrical Power Requirements</b>	
<b>5.3 Hooking things up</b>	
<b>5.4 Operating the machine</b>	
<b>5.5 Cleanup</b>	
<b>5.6 Troubleshooting</b>	
<b>6. Service and Maintenance</b>	<b>10</b>
<b>6.1 Foam Dome™ Pump Information</b>	
<b>6.2 Getting the most from your Foam Dome™ Pump</b>	
<b>7. Technical Data</b>	<b>10</b>
<b>8. Limited Warranty Conditions</b>	<b>11</b>

## **1. Set of Equipment Supplied**

- 1 Foam Dome™ Unit
- 1 Foam Dome™ pump with fittings
- 4' (1.2m) garden hose with male end for pump intake
- Switched electrical outlet strip
- 25' (7.6m) plastic tubing w/2ea push-con fittings
- Kit: Gloves, safety goggles and bolts
- “Keep Foam Fun” Safety Banner
- Instruction booklet, catalog, warranty card
- Shield set
- Note: you will need to provide a 55 gal. (208 l) plastic barrel with at least a 2” (5cm) opening

## **2. Accessories**

- Foam Dome™ Fluid Concentrate™ P/N 150125
- Foam Dome™ Outdoor Fluid Concentrate P/N 150125  
Available in 1 gal. (3.8 l), 5 gal. (19 l) and 55 gal. (208 l)  
Note: mix 1 gal. (3.8 l) concentrate with 50 gallons (189 l) water
- Foam Dome™ Fluid Ready-to-Use P/N 150120 (gallon (3.8 l))
- Tower Stand System (includes 2 telescope towers with 10' (3m) truss and T-bars P/N 250135)

**Please check whether all the products you ordered are supplied.**

### 3. Description of the Foam Dome™

The Foam Dome™ makes massive amounts of foam (210 cubic feet per minute (6 m<sup>3</sup> per minute)) quickly and harmlessly with its high-powered quiet fan. It will actually fill a 20' x 20' x 6' pit (6.1m x 6.1m x 1.8m) in less than 15 minutes. The improved white modulator has a thicker, higher output of foam. You can dance in it, ride through it and make clouds and snow effects with it. The Foam Dome™ uses a clean, white, harmless, biodegradable fluid, which will last 5 to 10 minutes in dry conditions and dry in six to eight hours. The Foam Dome™ is great for nightclubs, amusement park rides and special events. It works well in combination with colored lighting. The Foam Dome™ should be deployed over a non-skid surface such as indoor/outdoor carpeting.

### 4. Safety instructions

- o **RISK OF ELECTRICAL SHOCK:**
  1. Keep all electrical appliances away from the foam area.
  2. Do not touch Foam Dome™ or switched electrical outlet strip when wet.
  3. This device is to be used on normal distribution systems 230 VAC/10AMPS/50HZ. This device is designed to be used with the supplied switched electrical outlet strip. The switched electrical outlet strip has a grounding conductor. To reduce risk of electrical shock, connect only to a properly grounded, grounding type receptacle. Never remove the third prong from the plug on the switched electrical outlet strip, the pump or the Foam Dome™ unit (fan).
  4. Be aware of foam accumulations near the FOAM DOME™ electrical source/power box. Since the FOAM DOME™ is a very high output unit capable of extreme volumes of foam, place in an area, which allows full relief of foam from nozzle (front outlet) in all directions.
  
- o **SLIP HAZARD:** After turning on the switch on the switched electrical outlet strip, the machine will slowly start spraying small amounts of fluid, saturating the modulator with fluid. Once saturated, large volumes of foam will appear and continue to increase in size all around the modulator. The slippery substance of foam on a slick floor can create a dangerous environment, which could cause someone to fall. For safety reasons, the makers of the Foam Dome™ require using this machine or Foam Dome™ Fluid on a non-slip surface such as indoor/outdoor carpeting, turf, or asphalt.
  
- o **WARNING:** NEVER plug pump in without Foam Dome™ unit (fan) being on. Electrical damage to your motor will occur and as this would immediately void the one-year warranty.
  
- o **GLASS:** No glassware or breakables allowed in foam area. If glass breaks in foam area, evacuate all persons immediately until cleaned up.
  
- o **SUPERVISION:** No pushing, shoving or horseplay allowed. No diving, running or body bowling. Intoxicated individuals should leave foam area.

- o **EXPOSURE TO FOAM:** Avoid prolonged eye contact. Wash eyes with water if irritated. Always rinse body after having contact with foam just as you would after contact with soap, to prevent excess drying of skin. If irritation or allergic reaction occurs, individual should leave foam area immediately and wash irritated area. Do not wear soaked clothing for more than 4 hours without rinsing.

## 5. Operating the Foam Dome™

**WARNING:** FAILURE TO FOLLOW ALL SAFETY RULES AND INSTRUCTIONS LISTED BELOW MAY RESULT IN SERIOUS INJURY TO YOURSELF OR OTHER PARTICIPANTS OF THIS EFFECT.

### 5.1 Selecting the location

1. The slippery substance of foam on a slick floor can create a dangerous environment, which could cause someone to fall. For safety reasons, the makers of the Foam Dome™ require using this machine or Foam Dome™ Fluid on a non-slip surface such as indoor/outdoor carpeting, turf, or asphalt.
2. Make sure unit is in a well-supported and secure location before supplying power and fluid to unit. Shield should be facing the floor with the modulator (sock) pointing straight down. Never point modulator upward as this would cause electrical damage and ruin your unit.
3. The height of the machine above the drum decides how fast it will pump fluid. The higher the machine, the slower the fluid will flow through to the Foam Dome™. This unit is designed to be suspended 12' to 16' (3.7m to 4.9m) above the floor with the fluid on the floor. Never place fluid reservoir level with or higher than the Foam Dome™ as this will cause siphoning and dripping and will not stop fluid when turned off.

### 5.2 Electrical Power Requirements

1. This machine requires a grounded 230V/10Amp circuit for operation. The Foam Dome™ draws approximately 6 amps at 230 VAC. During Foam Dome™ operation this circuit should be dedicated to the Foam Dome™. If you have any doubts about the capacity or grounding of your existing circuits, consult a qualified electrician.
2. **You must have both units connected through the switched electrical outlet strip in order to use this device.**
  1. Plug switched electrical outlet strip into a well-grounded 230 VAC 10Amp outlet. If you have any doubt about the circuit's safety ground, plug-in testers are available to test the outlet. If in doubt, discontinue trying to power this unit until the outlet can be checked by an electrician.
3. **IMPORTANT!** Be aware of foam accumulations near the FOAM DOME™ electrical source/power box. Since the FOAM DOME™ is a very high output unit capable of extreme volumes of foam, place in an area, which allows full relief of foam from nozzle (front outlet) in all directions.

### 5.3 Hooking things up

1. Unpack crate and remove packing materials. Inspect Foam Dome™, pump and switched electrical outlet strip for any damage and notify CITC immediately if any problems occurred during shipping.
2. Hanging clamp is located behind the handle in the back. The safety cable is for properly hanging the unit. Locate in open area for foam to drop to the floor. Before hanging, test the fan in the Foam Dome™ unit to check for quiet operation. Hang vertically so the fluid nozzle is facing down toward the floor. The fan unit should spin freely without rubbing.
3. Mix fluid according to instructions. Never use concentrated fluid in this machine! Use either a plastic 55 gal. (208 l) drum (metal will rust), or use a clean trash container heavy enough to hold that much water. Note: Water weight is 426 lbs (193 kg)! While using eye protection and rubber gloves, clean container if necessary and fill with 50 gals. (189 l) of warm water first, then the 1 gal. (3.8 l) of concentrate (use 12.8 oz (379 ml) of concentrate for 5 gal (19 l) test). Mix by stirring without agitating. See warning statement (below) about proper safety features. Lower the hose from pump with hose attached to the pump into drum full of Foam Dome™ Fluid. Connect hose from the pump to the input hose connection on the Foam Dome™. Be sure rubber washers are always in place inside the hose connection before connecting. **DO NOT SUBMERGE THIS PUMP.**

#### **WARNING when mixing Concentrate: USE ONLY AS DIRECTED.**

**Handle concentrate with care.** Avoid contact with eyes. Concentrate is irritant to eyes. Wear eye protection and gloves when mixing. If concentrate contacts eyes, immediately wash with plenty of water, lifting eyelids for 15 minutes. Consult a physician. If contact with skin, wash with water. Prolonged contact with skin may cause irritation. Wash with water. If clothing is wet with material, change to clean clothes and wash affected skin. Not food quality. Do not ingest. If ingested, treat as dish soap. Odor from this product may be irritating to some individuals. Discontinue use and remove to fresh air. As with all surfactants, care must be used at all times. Rinse with plenty of water if contact occurs. Contact CITC for further questions or copies of the MSDS at 1-888-786-CITC or see it posted on our website at [www.citcfx.com](http://www.citcfx.com) under MSDS.

4. When running the hose from the pump back to the Foam Dome™, run the power cord from the Foam Dome™ unit (fan) with the hose all the way back to the Foam Dome™ making sure to keep them separated. The pump and the Foam Dome™ will then both be plugged into the switched electrical outlet strip. Be sure the power switch is in the OFF position before plugging in the pump. When powering up the Foam Dome™ unit (fan), note that the fluid will take some time to travel out before foam is produced. Never plug the pump into a wall outlet. It must be plugged into the outlet on the switched electrical outlet strip to insure that the pump does not come on unless the fan is on.

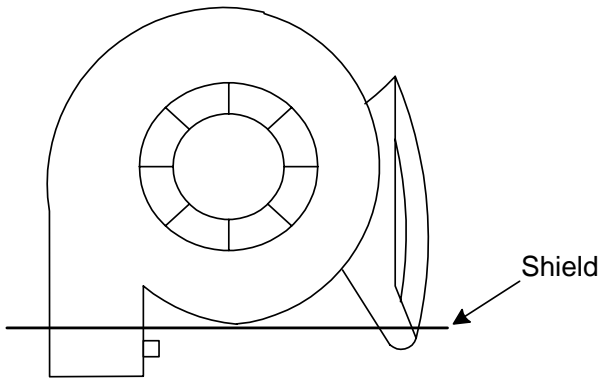

5. It is important to deploy the plastic shield enclosed in the unit. This plastic shield prevents most of the foam or bubbles from being sucked back inside the Foam Dome™ fan intake. Slide the shield half #1 onto the fan outlet, behind the modulator (sock) and under the tip of the molded handle located on the blower and molded strip under machine. Slide the shield half #2 onto the other side so that they come together. A hole lines up with hole from the other shield. Place the small bolt through the hole to connect the washer and nut. Tighten the nut securely, locking the shield in place.

6. Make sure unit is supported and secure before supplying power and fluid to unit. Shield should be facing the floor with the modulator (sock) pointing straight down. Never point modulator upward as this would cause electrical damage and ruin your unit.

## 5.4 Operating the machine

1. Review electrical connections: The power switch should be OFF. The switched electrical outlet strip should be plugged into a properly grounded outlet. Plug both the Foam Dome™ and the pump from the barrel into the switched electrical outlet strip. Both units need to always come on at the same time.
  - o **Warning:** You must have both units connected through the switched electrical outlet strip in order to use this device.
  - o **Never turn on the pump without the Foam Dome™ fan.** This will cause fluid to pour from fan area to floor. Unplug the pump if needing to test only the fan. When done, switch off the switched electrical outlet strip and plug pump in to switched electrical outlet strip to operate the system by switching on the pump and Foam Dome™ fan at the same time. **Never operate without all lines and hoses attached.**
2. Unit will turn on when you switch on the power switch on the switched electrical outlet strip. The machine will slowly start spraying small amounts of fluid, saturating the modulator with fluid. Once saturated, large volumes of foam will appear and continue to increase in size all around the modulator.
3. Note: Keep machine in a downward vertical position to allow fluid to flow out the front nose area (slightly tilted toward front). Do not run pump if fluid is unavailable. This may damage the pump.

4. The pump uses 5 gallons (19 l) in about 7 minutes. A 55-gallon drum of fluid (208 l) will last about 70 minutes. The Foam Dome™ will produce 210 cubic feet per minute (5.1 m<sup>3</sup> per minute) of foam, filling a 20' x 20' x 6' volume (6.1m x 6.1m x 1.8m) in less than fifteen minutes.

## 5.5 Clean up

- 1 Place a bucket under the modulator to catch falling water, and run 1-gallon (3.8 l) fresh water thru system each night to clean and freshen equipment. Unplug switched electrical outlet strip from power source. Wipe off output end and any excess foam. Make sure no fluid has dripped or splashed on the electrical components. Blow-dry with an air hose if necessary.
- 2 Clean up of the foam is easy. Some water may need to be mopped and removed. Use of a wet/dry vacuum may be needed.
- 3 Foam Dome™ Fluid is non-toxic, clean, easy to use and can be very fluffy. Fluid will not damage clothing. When mixing concentrate avoid eye contact and wash with water if eye or skin contact has occurred. Contact your local dealer or CITC with any questions you might have.

## 5.6 Troubleshooting

- o **If unit does not start:** Are the electrical connections tight? Check electrical power for properly grounded outlet. Check switched electrical outlet strip box (see instructions in section 3.2). Check power cord going to switched electrical outlet strip for cuts or separation
- o **If the fan is not operating:** Check Fan separately by disconnecting the pump from the switched electrical outlet strip. Does the fan rotate? Has foam gotten inside the unit? Is it wet? If so, disconnect the hose and blow out the unit with an air line. If not available, discontinue use until completely dry.
- o **If the fan rotates, but is not very fast:** Power loss will cause this unit to not function properly. Try plugging the fan into another outlet that is closer. Change the power switch on the unit to the faster speed. Does it rotate faster? You need to change to a heavier (minimum 12 awg) extension cord. Is the power supply dedicated solely to this unit? Are you sharing power with other equipment? Try disconnecting any other loads on the same circuit. If the fan rotates faster, then you need a dedicated power source.
- o **If you are not getting fluid to the Foam Dome™ unit:** Check pump separately by disconnecting from the hose and by disconnecting the fan from the switched electrical outlet strip and turning on the unit for a short time. If pump does not work, check another power outlet. If it still does not work, replace unit by calling for assistance.

- o **If the unit was foaming, then stops:**
  - o Check the intake hose of the pump in the bottom of the barrel. Is there sufficient fluid? Is there dirt in the bottom of the barrel? Keep the barrel clean and occasionally check to be sure dirt is not getting inside the barrel, as this will clog the pump. Shut off all power, disconnect the pump from the switched electrical outlet strip and remove the pump from the barrel. Disconnect the hoses and check for debris or dirt that may be clogging the unit. Connect the suction hose to the pump and plug in the pump separately to see the output, catching the output in a bucket. The output should be open and free.
  - o Check the nylon tubing going to the Foam Dome™ unit. Is it crimped or bent in a 90 degree angle? Change the tubing.
  - o Check the connection to the Foam Dome™ unit. There is a screen that will capture dirt from entering the nozzle. Disconnect the tubing and clean the screen at the connection. Reconnect and try again.
  - o If still clogged at the nozzle, remove unit to outside, connect a high-pressure hose to the nozzle connection. While holding the unit in it's hung position so the water will run down and out of the unit, (not up or in the unit), turn on the water to pressurize the nozzle inside and clean the nozzle. You should have plenty of pressure and volume to remove any clogged item. If still clogged, send the unit back to be serviced.
- o **If the modulator appears to yellow or change color:** Have you been rinsing the unit after each use? Dark areas that are warm are easy for bacteria to grow. Rinse and let the fan blow out the modulator after each use. Never leave the modulator (sock) wet or dripping with solution.

## 6. Service and Maintenance

### 6.1 Foam Dome™ Pump Information

The Foam Dome™ pump has built-in thermal overload protection, which means the unit will automatically shut-off when it senses it could reach an overheat level. Once cooled down, it will reset and is ready to pump again. Once the area to be drained reaches a maximum of 1/8" (0.32cm), unplug the pump or add more foam.

**NEVER place pump in fluid!** Unplug or switch off the unit when fluid has drained to 1/8" (0.32cm).

### 6.2 Getting the most from your Foam Dome™ Pump

Optimum performance is reached at a maximum 25' (7.6m) hose length. The pump continues to work at longer lengths.

Make sure the fluid runs smoothly through the hose with no kinks or obstructions! If there is little or no movement of fluid, that means either there is an air lock or something is clogging the unit. If the hose is not properly attached or have good rubber washers, it will reduce the foam output. If the unit is clogged, tip the pump upside down to eject any foreign object, then flush with fluid.

## 7. Technical Data

Foam Dome™ 230V Technical Data P/N 100212	
Foam Dome™ Dimensions	19" x 19" x 19" (48cm x 48cm x 48cm)
Foam Dome™ Weight	28 lbs (12 kg) (plus pump: see below)
Foam Dome™ Power	230 VAC 50 Hz, 6 A
Foam Dome™ Power Cord	25' (7.6 m)
Switched outlet strip	Four outlets with power switch
Fluid pump	High-pressure diaphragm pump 45 psi (3.1 bar) / 1.4gpm (5.3 lpm)
Wt/Dims fluid pump	5lbs (2.3 kg) / 7"x5"x5" (18x13x13cm)
Pump Power	230 VAC, 50 Hz, 0.35 A
Pump Power Cord	6ft (1.8 m)
Type of Fluid	Foam Dome™ fluid/water mix
Output	210 cubic feet per minute (6 m <sup>3</sup> per minute)
Fluid Consumption	Approx 0.7 gallon per minute (2.7 l/min)
Hose	5/8" x 25' (1cm x 7.6m) plastic
Barrel supplied by user	55gal (209 liter) plastic
Limited Warranty	One year
Rev: 12/11/03	

## **8. Limited Warranty Conditions for the Foam Dome™**

- 1. Subject to the following conditions we will repair any defect or fault in the unit if it is caused by a proven factory fault and has been advised immediately after appearance and within 30 days of delivery to the end user. Insignificant deviations of the regular product quality does not guarantee replacement rights, nor do faults or defects caused by water, by generally abnormal environment conditions or Force Majeure.**
- 2. Limited warranty Service will be done in the following way: Faulty parts will be repaired or replaced (our choice) with correct parts. Faulty units have to be shipped to us or sent to us at customer's expense. The RMA# has to come with the faulty, unit.**
- 3. The customer loses all rights for limited warranty services, if any repairs or adjustments are done to the units by unauthorized persons and/or if spare parts are used, which are not approved by us. The right of limited warranty service is also lost if a fluid other than the original "CITC Foam Dome™ fluid" has been used. Also, non-compliance with the instructions in this manual or mistakes by incorrect handling/treating of the machine, any faults and damages caused by undue force will lead to a loss of limited warranty.**
- 4. Freight costs to CITC when under the limited warranty services are the responsibility of the customer. CITC will pay freight upon return.**
- 5. Limited warranty services do not cause an extension of the limited warranty time or the start of a new limited warranty time. The warranty of replaced parts ends with the limited warranty time of the whole unit.**
- 6. If a defect/fault can not be repaired by us in a satisfactory time, we will, within 30 days after sale of the unit, our choice either:**
  - 1. Replace the whole unit for free or**
  - 2. Refund the lesser value or**
  - 3. Take back the whole unit and refund the purchase price, but not more than the usual market price at the time of refund.**
- 7. Further claims, especially for damages, losses etc. outside the unit are excluded.**

**If you should send the unit for service, obtain your RMA # by calling CITC. Payment arrangements for repair must be made before receiving RMA # in case unit is not covered under Limited Warranty.**

**Send unit to:**

**CITC  
RMA # XXXXXXX  
2100 196<sup>th</sup> Street SW Suite #138  
Lynnwood, WA 98036  
Tel: (888) 786-CITC or (425) 776-4950  
Fax: (425) 776-5129  
Website: [www.citcfx.com](http://www.citcfx.com)  
E-mail: [info@citcfx.com](mailto:info@citcfx.com)**



**2100 196<sup>th</sup> St. SW, #138, Lynnwood, WA 98036-7083  
425-776-4950 ✧ FAX: 425-776-5129  
[www.citcfx.com](http://www.citcfx.com) ✧ [info@citcfx.com](mailto:info@citcfx.com)**

December 11, 2003